

## DESCRIPTION

The Camlok LJ series of plate clamps can be used to lift and turn all structural steel plates, stainless steel, iron, timber and aluminium without marking or damaging the surface. The clamp may not be suitable for lifting highly polished plates where the polishing process may leave behind lubricating compounds. The performance of the leather jaws is not affected by standing water so the clamp can be used with submerged plasma cutting machines etc. The clamp is also suitable for steels with a surface hardness above 300 Brinell.

## DIAGRAM

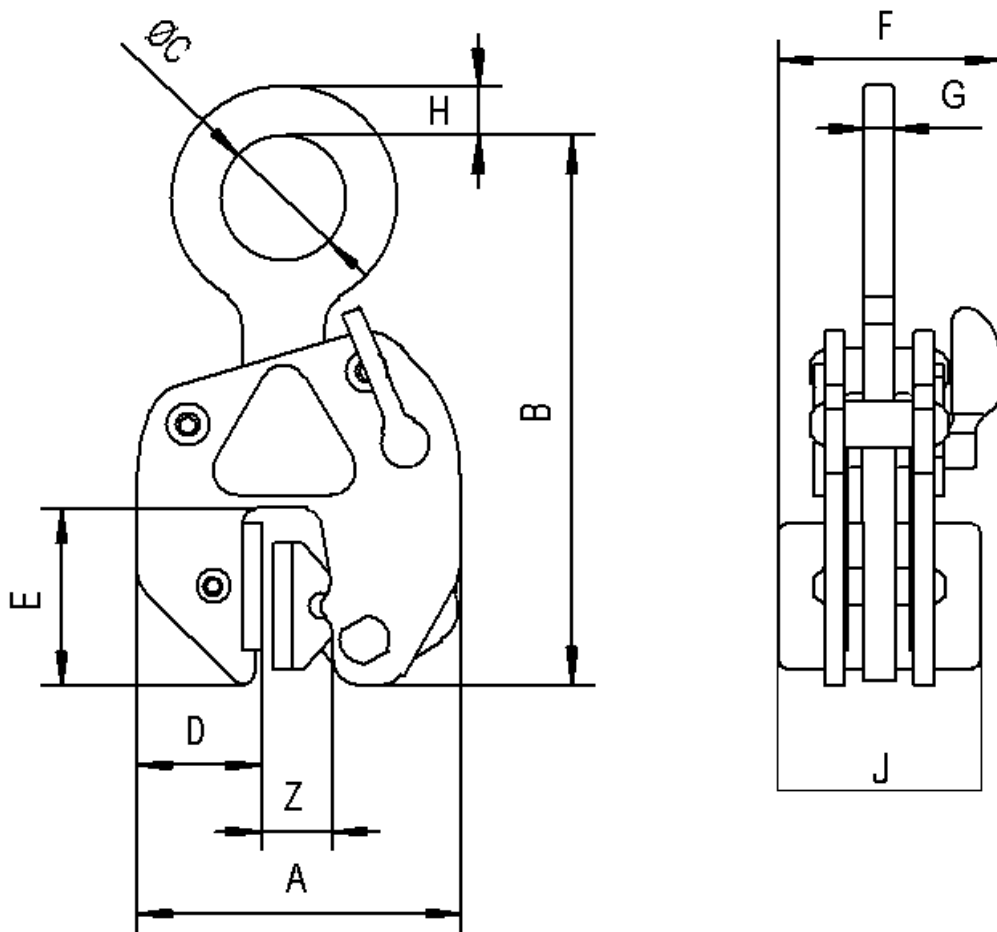

## TABLE

MODEL	WLL Tons	Plate mm Z	Weight kg	A	B	C	D	E	F	G	H	J
LJ0.5	0.5	0-10	3	127	200	55	52	69	86.5	76	20	76
LJ1.5	1.5	0-20	20	215	345	85	75	135	131	118	24	118

### Load Diagram with slings vertical

Loads weighing the maximum W.L.L may be lifted and turned through 180 degrees in the plane of the clamp

Load must hang no more than 15 degrees when suspended by the clamp only.

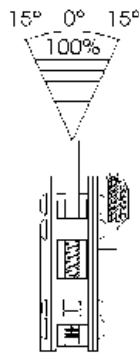
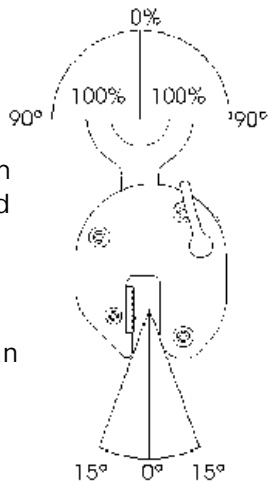

Loads weighing the maximum W.L.L may be lifted through 15 degrees in the plane of the clamp

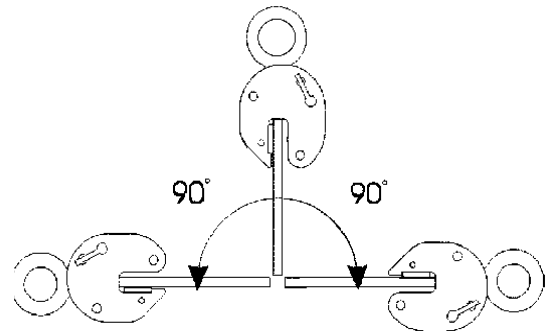

### RESTRICTIONS

The working load limit of the clamp should be as close as possible to the actual load to be lifted. This ensures that the clamp is working at maximum efficiency. Extra care must be taken when lifting plates in the lower 20% of the rated jaw capacity, these thin plates are best lifted with the fixed jaw on top. DO NOT use solvents to clean the jaw lining as this may effect the bond between the surface material and the metal of the jaw.

#### FOR SHORT PLATES

A single clamp can be used

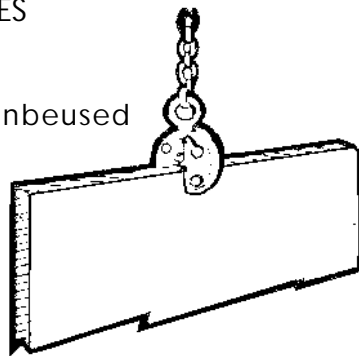

#### FOR LONG PLATES

2 clamps and a lifting beam must be used

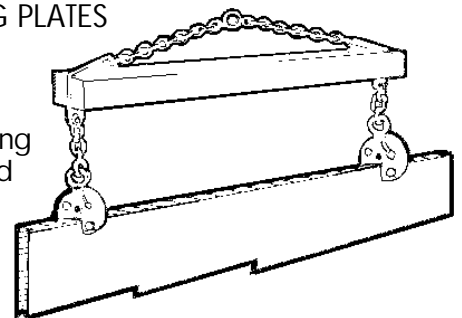

### OPTIONS

Camlok The LJ gentle grip plate clamp offers several alternatives including size and the replacement of the leather jaw with soft rubber pads. The standard clamp is fitted with a cam operated locking mechanism, however if preferred the cam operated locking mechanism can be replaced with a chain pull system.

