

DESCRIPTION

The Camlok series of high grip plate lifting clamps can be used on all structural steel plates and sections up to a surface hardness of 376 Brinell. They develop a much higher grip on the plate than the normal universal type and can be used for lifting and turning plates from the horizontal to vertical and back to the horizontal through 180° or vice versa. They are particularly useful for lifting stainless steel or plates with hardened surfaces due to cold rolling.

DIAGRAM

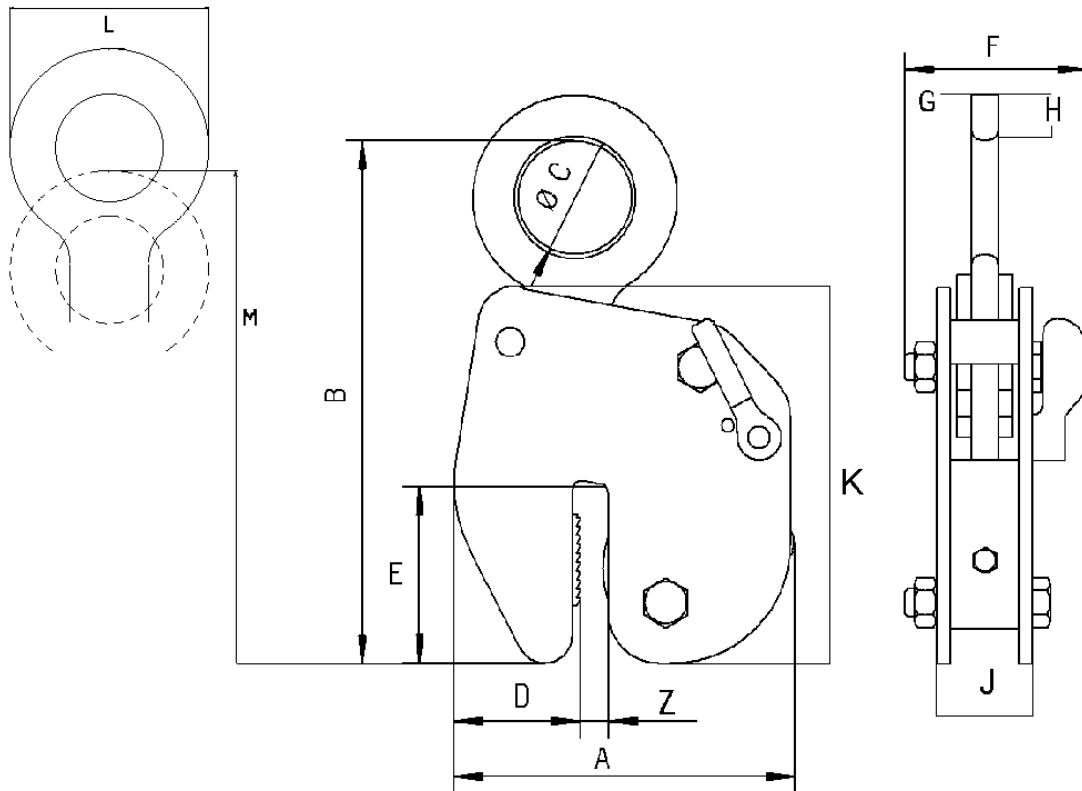

TABLE

MODEL	WLL Tons	Plate mm Z	Weight kg	A	B	C	D	E	F	G	H	J	K	L
HG0.5	0.5	0-10	5	148	230	50	79	55	80	13	20	42	165	90
HG1	1	0-16	12	210	297	67	114	75	93	13	20	60	219	108
HG2	2	0-20	22	305	416	80	159	102	110	20	32	70	317	140
HG3	3	0-20	27	305	416	80	159	102	110	20	32	70	317	140
HG4	4	0-20	32	305	435	89	158	102	120	20	32	80	317	158

Load Diagram with sling vertical

Loads weighing the maximum W.L.L may be lifted and turned through 180 degrees in the plane of the clamp

Load must hang no more than 15 degrees when suspended by the clamp only.

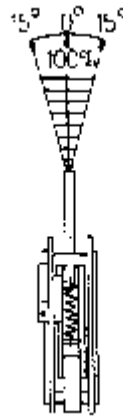
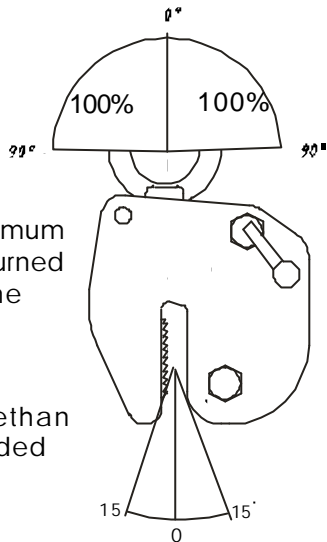

Loads weighing the maximum W.L.L may be lifted through 15 degrees in the plane of the clamp

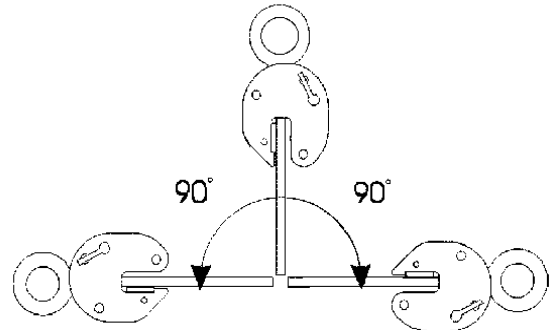

RESTRICTIONS

The clamp is not suitable for steel over 376 Brinell, lead, certain grades of copper and materials over 120° surface temperature. The working load limit of the clamp should be as close as possible to the actual load to be lifted. This ensures that the clamp is working at maximum efficiency. Loads below 20% of the working load limit should be avoided extra care must be taken when lifting plates in the lower 20% of the rated jaw capacity. Excessive wear and a reduction in working life can be caused if a clamp is continuously used to lift the same thickness material. NB. This clamp will mark the surface of the material being lifted

FOR SHORT PLATES

A single clamp can be used

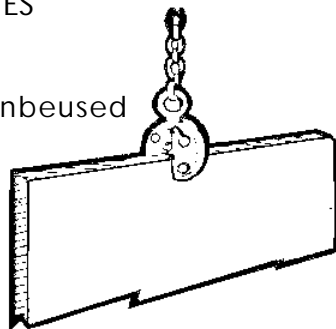

FOR LONG PLATES

2 clamps and a lifting beam must be used

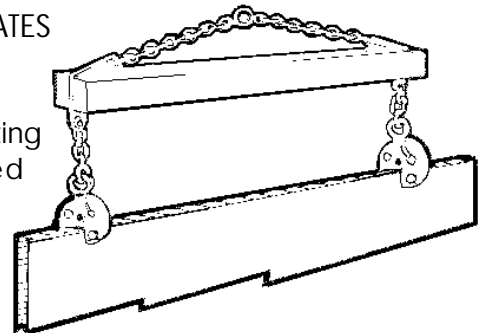

OPTIONS



The standard clamp is fitted with a hook ring but can alternatively be supplied with a short length of chain and masterlink. This aids in the attachment to larger crane hooks and prevents accidental release when fast lowering. Additional jaw sizes are also available. Call our sales team to find out more.

